

PRODUCT NO.
52486-050HA/050HALF

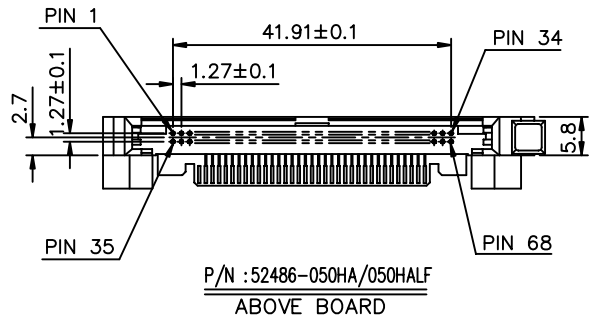
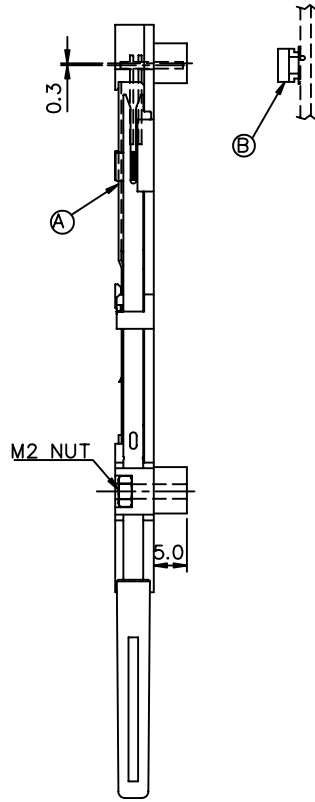
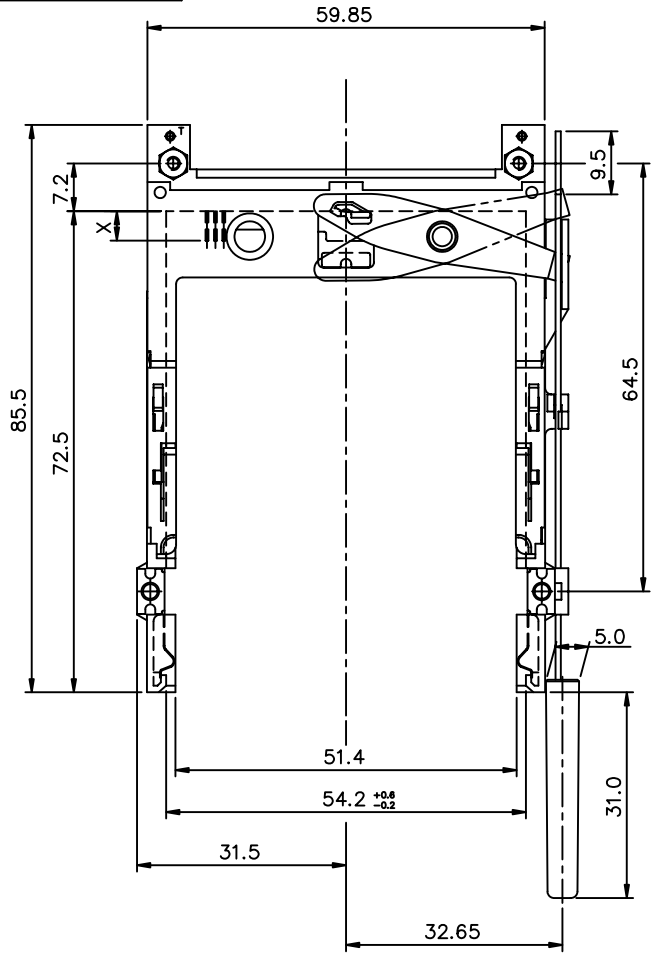

P/N : 52486-050HA/050HALF
ABOVE BOARD

NOTES:

1. 8mm MIN. CARD EJECT.
2. EJECT TRAVEL: 9.5mm
3. MATERIAL
 - 3.1 HEADER ASS'Y
 - PLASTIC : HOUSING ...LCP UL94V-0 BLACK
 - PIN : COPPER ALLOY
 - PCB : FR4
 - 3.2 EJECT MECHANISM ASS'Y
 - PLASTIC : GUIDE: POLYPHTHAMID UL94V-0 BLACK
 - : BUTTON: POLYPHTHAMID UL94V-0 BLACK
 - PLATE : STAINLESS
 - EMI CONTACT: PHOSPHOR BRONZE
 - 3.3 RECEPTACLE
 - PLASTIC : LCP 94V-0, NATURAL.
 - PIN: BeCu
4. FINISH (PIN)
 - UNDER PLATING : 0.5 um MIN. Ni
 - CONTACT AREA : 0.1 um MIN. GOLD OVER
 - 0.5 um MIN. Pd-Ni
 - SOLDER TAIL : 2.5 um MIN. Sn-Pb
 - : 2.5 um MIN. PURE Sn (FOR -050HALF)
- ⑤ PUSH ROD LOCATION AND P.C.B. SIDE ARE AS APPEARS INSTALLED.
6. DIM "X"

4.25±0.1	3.5±0.1	5.0±0.1
OTHERS	36,67	1,17,34,35,51,68

7. P.C.B LAYOUT REFERED TO TA-1052.
8. IF LEAD FREE P/N. THE HOUSING WILL WITHSTAND EXPOSURE TO 260°C PEAK TEMPERATURE FOR 10 SECONDS IN A WAVE SOLDER APPLICATION WITH A 1.00MM MINIMUM THICK CIRCUIT BOARD.
9. LEAD FREE PRODUCT MEETS EUROPEAN UNION DIRECTIVES AND OTHER COUNTRY REGULATIONS AS DESCRIBED IN GS-22-008
10. IF LEAD FREE P/N. PACKAGING MEETS GS-14-920 SPECIFICATION

ORDERING INFORMATION

NAME	PART NO.	Q'TY
Ⓐ EJECT HEADER ASS'Y	52486-050HA/050HALF	1
Ⓑ MATING RECEPTACLE	91931-31169/31169LF	1

mat'l code		tolerance unless otherwise specified		CUSTOMER COPY				
rev.	ecn no.	dr	date	linear	± 0.30	projection	title	
A	T90421	M	W12/17/99			⊕	EJECTOR HEADER ASS'Y	
B	T20085	WL	03/18/02				68POS. FOR TYP 1/2/3	
C	N05-0128	WB	05/20/05	angles	± 2°			
		dr	WENDY CHEN 08/30/99	unit		product family : PCMCIA		
		enrg	STELAR CHU 08/30/99	mm/inch		size	code	
		chr	JOSEPH HSIA 08/30/99	scale		dwg no.	TWN	
		appd	LELAND WANG 08/30/99	1.2:1		52486	sheet	
sheet	revision							1 OF 1
index	sheet							

Tous droits strictement reserves. Reproduction ou communication a des tiers int sous quelque forme que ce soit sans autorisation ecrite du proprietaire. Propriete de c BERG ELECTRONICS. Droits de reproduction BERG ELECTRONICS by

FCI

All rights strictly reserved. Reproduction or issue to third parties in any for whatever is not permitted without written authority from the proprietor. Property of c BERG ELECTRONICS. Copyright BERG ELECTRONICS by